

Séries  
NSX

SIZE 1 COAXIAL SOCKET CONTACT WITH TNC ADAPTOR  
BOEING SPEC. BACC 47EN-4

Issue:  
23 APRIL 93

Page  
1/2

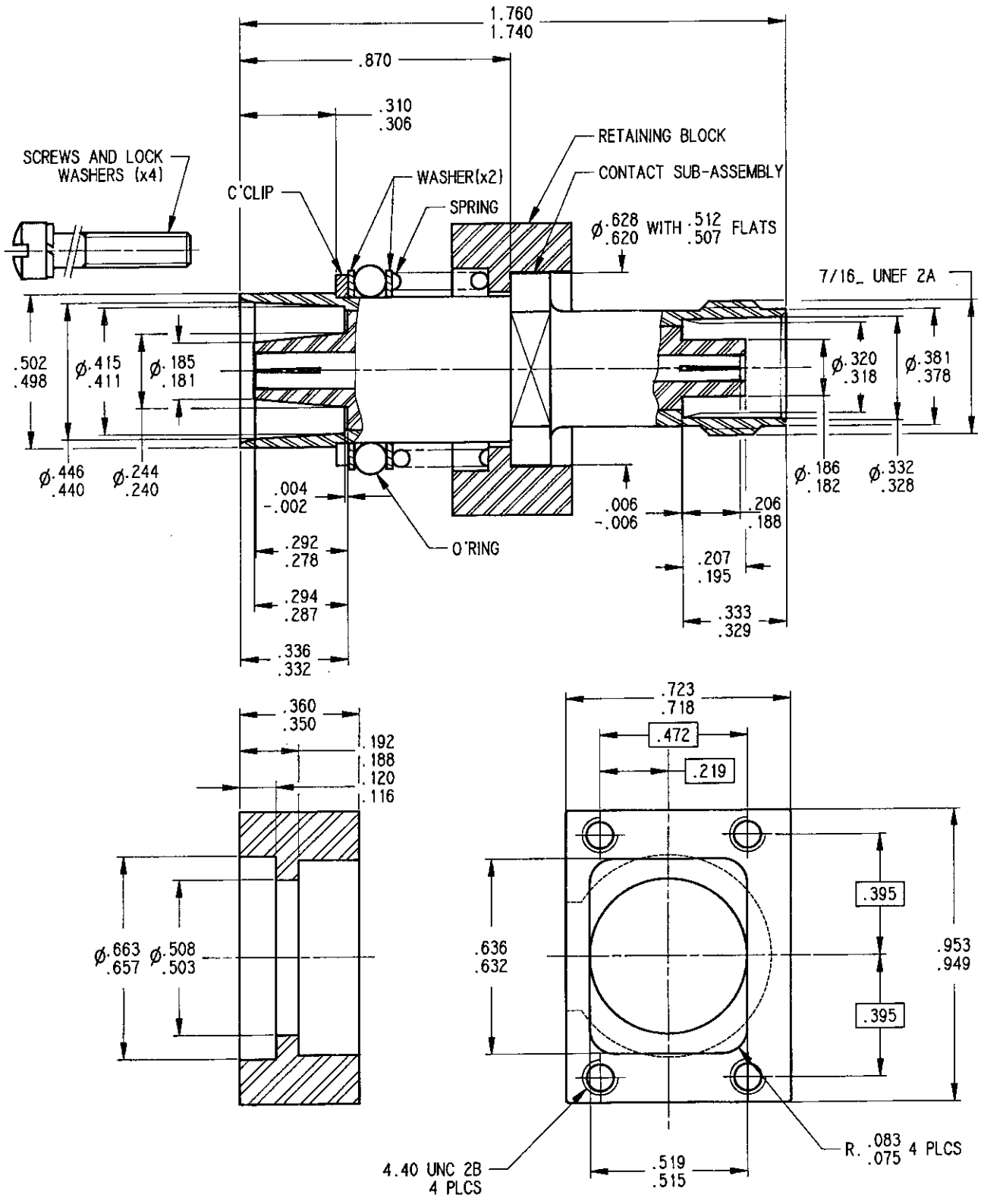

This information is given as an indication in the continual goal to improve our products, we reserve the right to make any modifications judged necessary.

CREATION			
PEN: .			
EP: .			
Name: L FALETTI	23.04.93	ADDED PAGE 2/2	JP MACARI
Date: 27 JULY 92	24.03.93	.512/.507 WAS .500/.498 .360/.350 WAS .310/.304 .519/.515 WAS .508/.503	JP MACARI
	Issue	Revisions	Name

LOCK WASHERS	SPRING STEEL	CADMIUM YELLOW CHROMATE
SCREWS	STAINLESS STEEL	PASSIVATED
FLAT WASHERS	STAINLESS STEEL	PASSIVATED
SPRING	STAINLESS STEEL MUSIC WIRE	PASSIVATED
RETAINING BLOCK	ALUMINUM ALLOY PER QQ.A.591	BLACK ANODIZED BY MIL.A.8625
O_RING AND GASKET	FLUOROSILICONE PER MIL.R.25988	NONE
DIELECTRIC	PTFE PER MIL.S.19468	NONE
CENTER CONTACT	BERYLLIUM COPPER PER QQ.C.530 HEAT TREATED	.00004 GOLD PER MIL.G 45204 OVER .0001 OF NICKEL PER QQ.N.290
OUTER CONTACT BODY BRAID CLAMP_WASHERS CLAMP NUT	BRASS PER QQ.B.626	.00002 GOLD PER MIL.G 45204 OVER .0001 OF NICKEL PER QQ.N.290
COMPONENT DESIGNATION	MATERIAL	FINISH

ELECTRICAL CHARACTERISTICS  
 TEMPERATURE RANGE: -65°C TO +125°C  
 IMPEDANCE: 50Ω NOMINAL

PERFORMANCE REQUIREMENTS

FREQUENCY RANGE (GHz)	VSWR (MAX)	INSERTION LOSS (dB MAX)
0 - 2	1.35:1	.15
2 - 3	1.70:1	.30

This information is given as an indication. In the continued goal to improve our products, we reserve the right to make any modifications judged necessary.

Issue	Revisions	Name